

Released Form

Student Name: _____

Spring 2013
North Carolina
Measures of Student Learning:
NC's Common Exams
**Common Core
Integrated Math III**



Student Booklet



Public Schools of North Carolina
State Board of Education
Department of Public Instruction
Raleigh, North Carolina 27699-6314

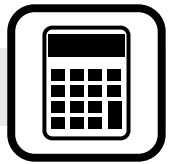

- 1 Which expression is equivalent to $(x + 3)^3 - 9x(x + 3)$?
- A $x^3 + 27$
- B $x^3 - 27$
- C $x^3 - 9x^2 - 27x + 27$
- D $x^3 - 9x^2 + 27x + 27$
- 2 Suppose $p(x) = x^3 - 2x^2 + 13x + k$. The remainder of the division of $p(x)$ by $(x + 1)$ is -8 . What is the remainder of the division of $p(x)$ by $(x - 1)$?
- A -8
- B 8
- C 16
- D 20
- 3 What is the **approximate** solution to the equation $3^{x-1} = 4^{2x+5}$?
- A 3.875
- B 1.262
- C -2.354
- D -4.797

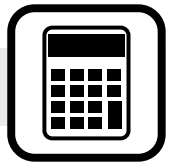

- 4 The value of an account that is being compounded continuously is given by the formula $A = Pe^{rt}$, where P is the principal, r is the annual interest rate, and t is the time in years. **Approximately** how long will it take for the amount of money to double if the interest rate is 2.4%?
- A 11.0 years
 - B 12.9 years
 - C 20.0 years
 - D 28.9 years
- 5 A principal wants to survey 150 students to determine which electives to offer during the next school year. There are 1,800 students in the school. Which procedure could the principal use to select a sample using a systematic random sample?
- A Obtain a list of all students. Start with the eighth student, and select every twelfth student until 150 students have been selected.
 - B Select the first 150 students who enter the school.
 - C Choose the fifth student to come into the cafeteria, and then select every third student who comes into the cafeteria until 150 students have been selected.
 - D Place students' names on slips of paper and select 150 slips.
- 6 There are two candidates running for office. In a poll of 1,065 voters, where voters had to select one of the two candidates, 615 favor Candidate One. What is the sample proportion for those who favor Candidate Two?
- A 0.33
 - B 0.42
 - C 0.58
 - D 0.67

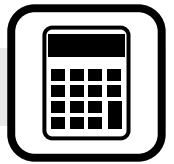

- 7 What is the solution to the equation below?

$$\frac{\frac{3}{x} + 2}{\frac{x}{5} + 1} = \frac{15}{x}$$

- A -12
B -2
C 2
D 12
- 8 A system of equations is shown below.

$$y = |x - 3|$$

$$y = \frac{1}{2}x$$

What is the distance between the points of intersection of the system?

- A $\sqrt{6}$
B $\sqrt{20}$
C $\sqrt{48}$
D $\sqrt{80}$

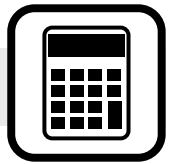

- 9 What value of h is needed to complete the square for the equation $x^2 + 10x - 8 = (x - h)^2 - 33$?
- A -25
B -5
C 5
D 25
- 10 A right rectangular prism is shown below.

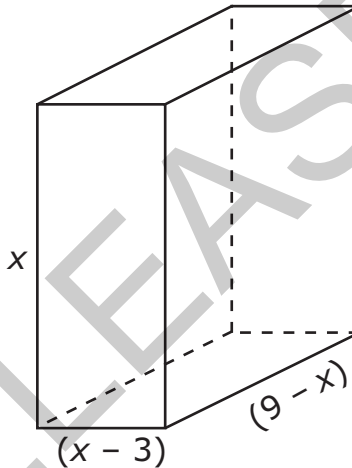

What is the domain for the volume function of the prism?

- A $0 < x < 9$
B $0 < x < 3$
C $3 < x < 9$
D $6 < x < 9$

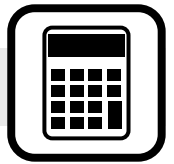

- 11 Which statement is true about the asymptotes of $g(x) = \frac{2x^2 + 4x + 2}{x^2 - 1}$ and the function f graphed below?

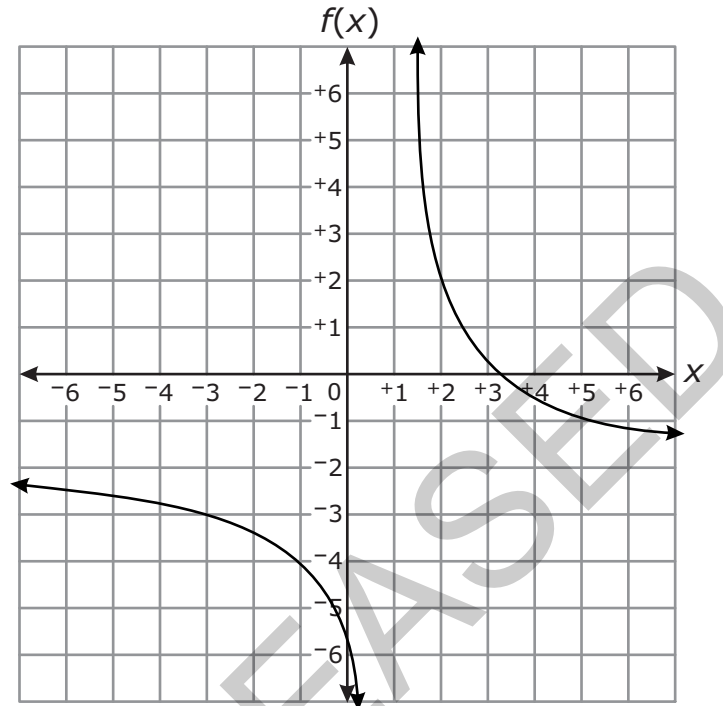

- A The horizontal asymptote of $f(x)$ lies below the horizontal asymptote of $g(x)$.
- B The horizontal asymptote of $f(x)$ lies above the horizontal asymptote of $g(x)$.
- C The number of vertical asymptotes of $f(x)$ is less than the number of vertical asymptotes of $g(x)$.
- D The number of vertical asymptotes of $f(x)$ is greater than the number of vertical asymptotes of $g(x)$.

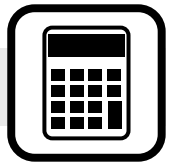

12 What is the value of x if $\frac{h+5}{x} - 3 = 12$?

A $x = \frac{h}{10}$

B $x = \frac{h}{3}$

C $x = \frac{h}{3} + \frac{1}{3}$

D $x = \frac{h}{15} + \frac{1}{3}$

13 Fred drives an average of 15,000 miles per year, and his car gets 20 miles per gallon of gasoline.

- The average cost of gasoline is \$3.25 per gallon.
- He buys a new car.
- In his new car, Fred continues to average 15,000 miles per year, and the average cost of gasoline remains the same.

Approximately how many more miles per gallon does the new car get if Fred has a savings of \$650 per year on gasoline?

A 5.8 mpg

B 7.3 mpg

C 8.8 mpg

D 10.3 mpg

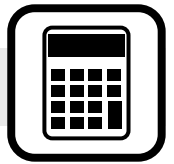

- 14 A town has 685 households. The number of people per household is normally distributed with a mean, μ , of 3.67 and a standard deviation, σ , of 0.34. **Approximately** how many households have between 2.99 and 4.01 people?
- A 493 households
 - B 520 households
 - C 558 households
 - D 575 households
- 15 The scores on a recent test are normally distributed. John's test score of 69 was 1 standard deviation below the mean. Betty's test score of 99 was 3 standard deviations above the mean. What are the mean and standard deviation for the test score distribution?
- A The mean is 76.5, and the standard deviation is 7.5.
 - B The mean is 79, and the standard deviation is 10.
 - C The mean is 84, and the standard deviation is 15.
 - D The mean is 91, and the standard deviation is 2.5.
- 16 County X has a population density of 250 people per square mile. The total population of the county is 150,000. Which geometric model could be the shape of county X?
- A a parallelogram with a base of 25 miles and a height of 25 miles
 - B a rectangle that is 15 miles long and 45 miles wide
 - C a right triangle with a leg that is 30 miles long and a hypotenuse that is 50 miles long
 - D a trapezoid with base lengths of 10 miles and 30 miles and a height of 25 miles

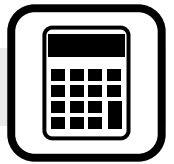

- 17 The volume of a rectangular prism is represented by the expression $(x^3 - 2x^2 - 20x - 24)$. If the length is $(x - 6)$ and the height and width are equal, what is the width of the prism?
- A $x + 2$
- B $x - 2$
- C $x + 4$
- D $x - 4$
- 18 William put the tip of his pencil on the outer edge of a graph of the unit circle at the point $(0, -1)$. He moved his pencil tip through an angle of $\frac{4\pi}{3}$ radians in the counterclockwise direction along the edge of the circle. At what angle of the unit circle did William's pencil tip stop?
- A $\frac{\pi}{3}$
- B $\frac{5\pi}{6}$
- C $\frac{7\pi}{6}$
- D $\frac{5\pi}{3}$

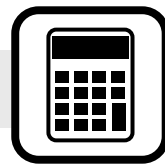

- 19 Astronomers have observed that sunspots vary sinusoidally. The variation is from a minimum of about 10 sunspots per year to a maximum of about 120 per year. A cycle lasts about 11 years. If a minimum occurred in 1964, which function could model the number of sunspots, S , as a function of the year, t ?
- A $S(t) = -55\cos\left(\frac{2\pi}{11}(t - 1964)\right) + 65$
- B $S(t) = -55\cos\left(\frac{2\pi}{11}t - 1964\right) + 65$
- C $S(t) = -65\cos\left(\frac{2\pi}{11}(t - 1964)\right) + 55$
- D $S(t) = -65\cos\left(\frac{2\pi}{11}t - 1964\right) + 55$
- 20 A plane intersects a regular triangular pyramid. The plane is parallel to one of the faces of the pyramid. What type of polygon is formed at the intersection?
- A square
- B right triangle
- C isosceles trapezoid
- D isosceles triangle

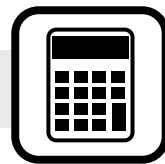

- 21 A gardener is trying to decide which seeds to plant in the garden. A certain vegetable has a 60% chance of growing. Of those 60%, only 25% actually produce the vegetable the first year it is planted. The gardener will only plant the vegetable if it has a 25% or greater chance of producing the vegetable the first year. Will the gardener plant this vegetable?
- A Yes, there is an 85% chance that the planting will result in vegetables the first year.
- B Yes, there is a 60% chance that the planting will result in vegetables the first year.
- C No, there is only a 20% chance that the planting will result in vegetables the first year.
- D No, there is only a 15% chance that the planting will result in vegetables the first year.
- 22 Which is the inverse of $f(x) = 1.5^x + 4$?
- A $f^{-1}(x) = \frac{x - 4}{1.5}$
- B $f^{-1}(x) = \frac{\log(x) - 4}{1.5}$
- C $f^{-1}(x) = \frac{\log(x - 4)}{\log(1.5)}$
- D $f^{-1}(x) = \frac{4 - \log(x)}{\log(1.5)}$

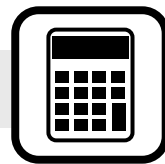

- 23 The surface area of a balloon can be represented by the function $S(r) = 4\pi r^2$, where r is the radius of the balloon. If r increases with time, t , and is represented by the function $r(t) = \frac{1}{4}t^2$, what is the surface area of the balloon expressed as a function of time?

A $S(t) = 4\pi t^2$

B $S(t) = \pi t^2$

C $S(t) = \frac{\pi t^4}{4}$

D $S(t) = \frac{\pi^2 t^2}{16}$

- 24 What is the **approximate** value of the sum:

$$8 - \frac{8}{7} + \frac{8}{49} - \dots + 8 \cdot \left(\frac{-1}{7}\right)^{2,500} ?$$

(Note: The sum of a series can be calculated using the formula $S_n = \frac{a_1(1 - r^n)}{1 - r}$, where $r \neq 1$.)

- A 1
B 7
C 8
D 9

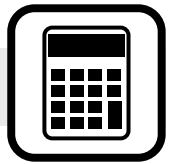

25 If t is an unknown constant, which binomial must be a factor of $7m^2 + 14m - tm - 2t$?

- A $7m + t$
- B $m - t$
- C $m + 2$
- D $m - 2$

This is the end of the multiple-choice portion of the test.

RELEASED

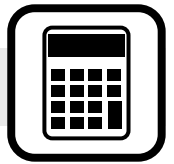

The questions you read next will require you to answer in writing.

1. Write your answers on separate paper.
2. Be sure to write your name on each page.

- 1 Cindy purchased 100 bricks. Each brick is within $\frac{1}{8}$ inch of the advertised length of 8 inches. Cindy will line the bricks up end to end, with no space between them, to build a straight line path.
- Write a single inequality that can be used to find the possible lengths of the path.
 - What is the minimum length of the path?
 - What is the maximum length of the path?

RELEASED

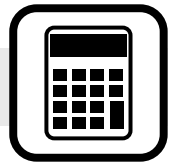

- 2 A farmer's plot of land contains four equal-sized planting areas (labeled Type A) surrounding a fifth circular planting area as shown below.

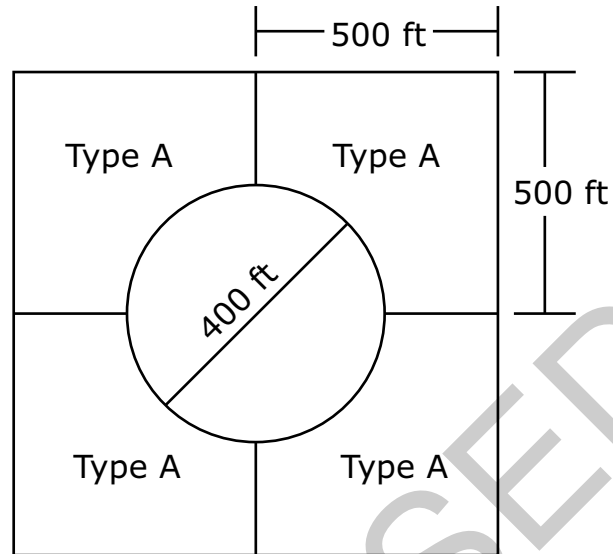

The farmer will plant lettuce, potatoes, and corn. Each planting area will contain only 1 crop. Each crop will be planted in at least 1 planting area. At least 25% of the total area will be potatoes.

Suppose each plant takes up one square foot of land. The farmer can buy lettuce plants for \$0.50 each, potato plants for \$0.75 each, and corn plants for \$1.00 each.

- What is the area, to the nearest square foot, of 1 of the noncircular planting areas (Type A)?
- Which crop should the farmer plant in the circular region to minimize the total cost of the plants? Explain.
- What is the minimum cost to plant all 5 regions?

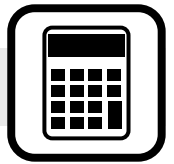

3 Given the function:

$$g(x) = \frac{(x - 2)(3x + 2)}{(x + 4)(x - 2)(x - 6)}$$

- What are the equations of the asymptotes of the function?
- Determine if there are any points of discontinuity. Explain why or why not.
- Describe the end behavior as x approaches $-\infty$, and as x approaches $+\infty$.

RELEASED



This is the end of the Common Core Integrated Math III test.

- 1. Look back over your answers.**
- 2. Put all of your papers inside your test book and close the test book.**
- 3. Place your calculator on top of the test book.**
- 4. Stay quietly in your seat until your teacher tells you that testing is finished.**

RELEASED



Common Core Integrated Math III
RELEASED Form
Spring 2013
Answer Key

Item number	Type	Key	Conceptual Category
1	MC	A	A — Algebra
2	MC	D	A — Algebra
3	MC	D	F — Function
4	MC	D	F — Function
5	MC	A	S — Statistics and Probability
6	MC	B	S — Statistics and Probability
7	MC	A	A — Algebra
8	MC	B	A — Algebra
9	MC	B	F — Function
10	MC	C	F — Function
11	MC	A	F — Function
12	MC	D	A — Algebra
13	MC	B	A — Algebra
14	MC	C	S — Statistics and Probability
15	MC	A	S — Statistics and Probability
16	MC	C	G — Geometry
17	MC	A	A — Algebra
18	MC	B	F — Function
19	MC	A	F — Function
20	MC	D	G — Geometry
21	MC	D	S — Statistics and Probability
22	MC	C	F — Function
23	MC	C	F — Function

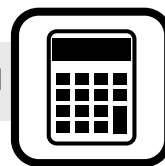

Item number	Type	Key	Conceptual Category
24	MC	B	A — Algebra
25	MC	C	A — Algebra
26	CR	Rubric	A — Algebra
27	CR	Rubric	G — Geometry
28	CR	Rubric	F — Function

Item Types:

MC = multiple choice

CR = constructed response

RELEASED